

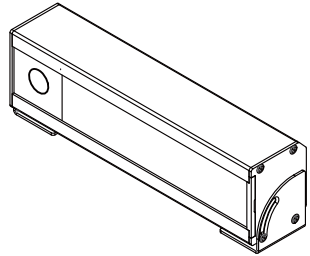

# Wide Dynamic Range NamePlate Surveillance Camera Sheet



690HTVL-E High Resolution

## Template

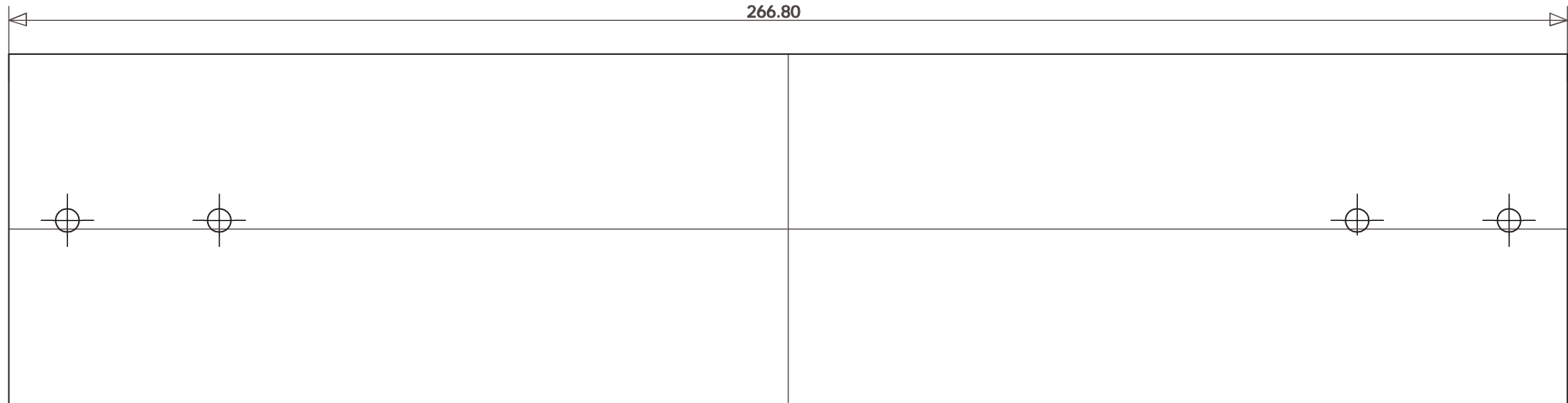

## Camera Installation and Connection

### Installation

1. Use template to mark appropriate location for the mounting brackets.
2. Remove the 2 bottom screws on each side of the camera housing.
3. Place the camera housing into the positioned brackets.
4. Use a screwdriver to tighten and secure the camera housing. Adjust the position required and tighten the screws so as to fix the camera housing to the desired view angle.
- 5-8. To replace the front face plate, remove the end cap and slide out the existing plate. Slide in the new name plate and replace the end cap.

Note: There is a wire access hole in the back and bottom of the nameplate housing. Choose which point to use based on the installation.

### Connection

Use the wire ended barrel plug to attach the appropriate power source and plug into the mating connector coming off the dual power board. Attach video cable and installation is complete.

Make sure power is off before any connection is made.

## Parts and Descriptions

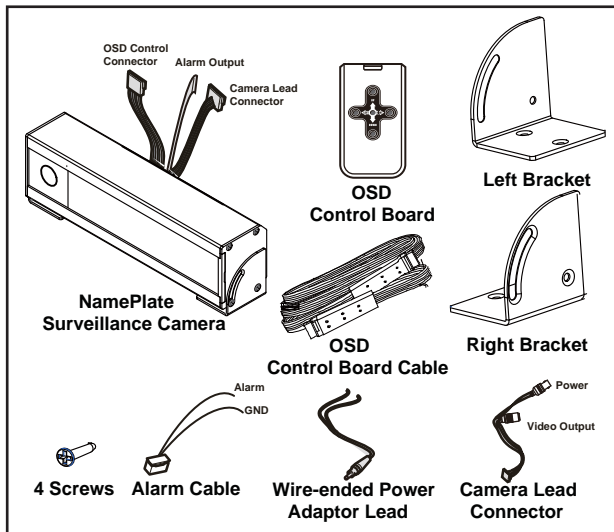

### Installation

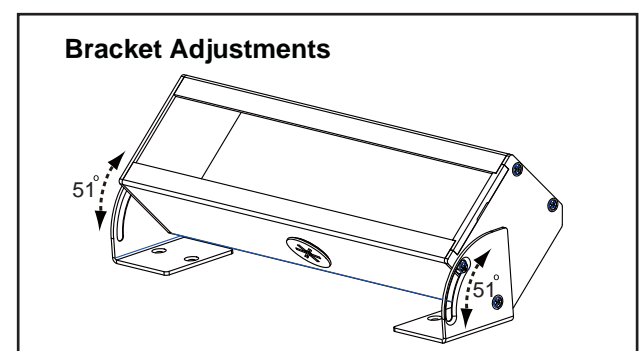
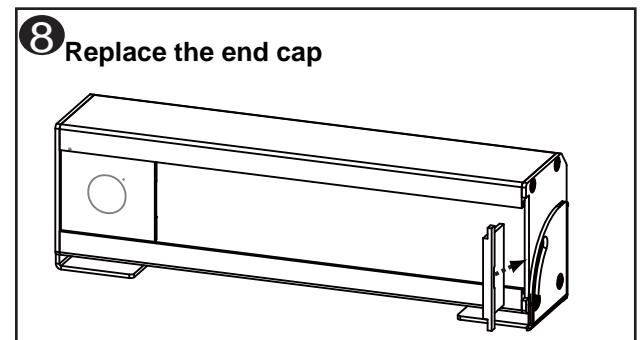
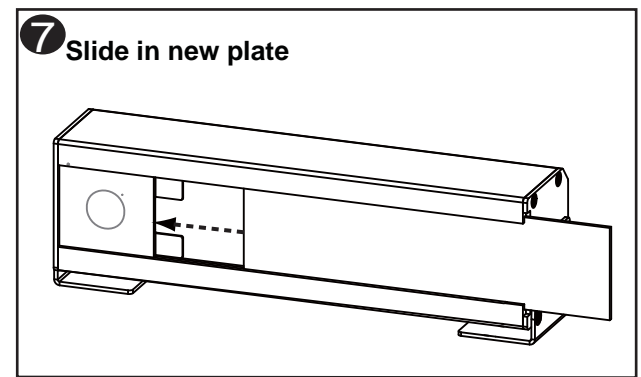
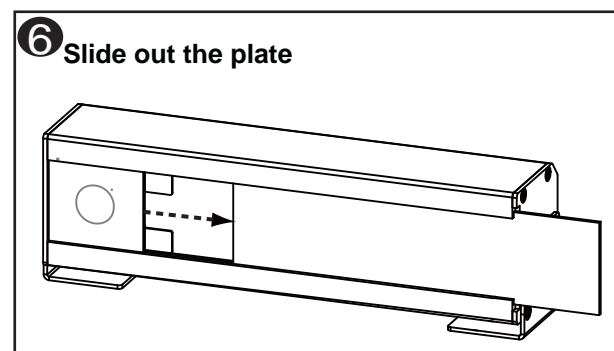
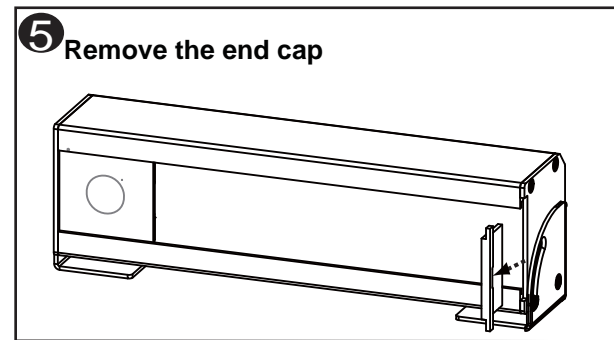
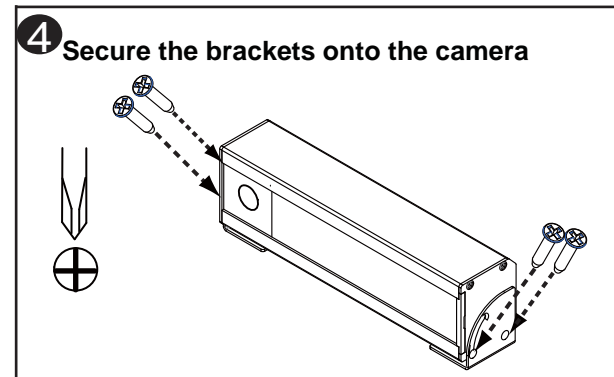
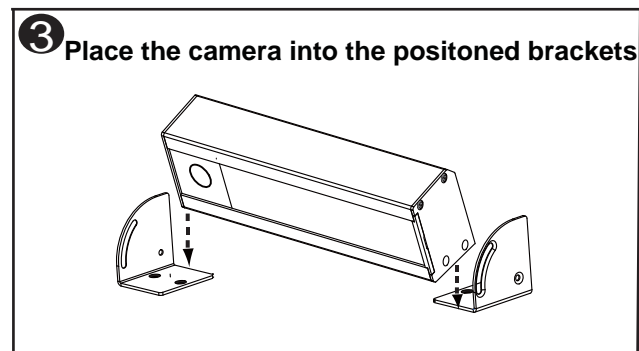
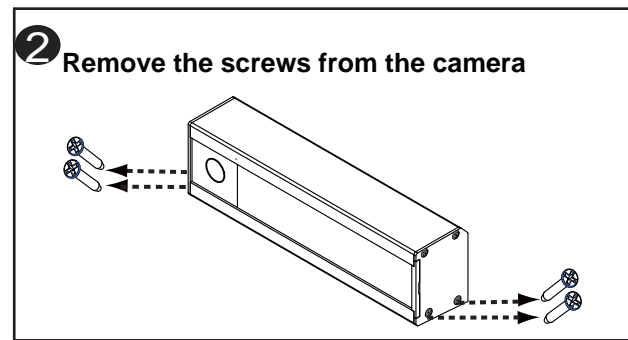
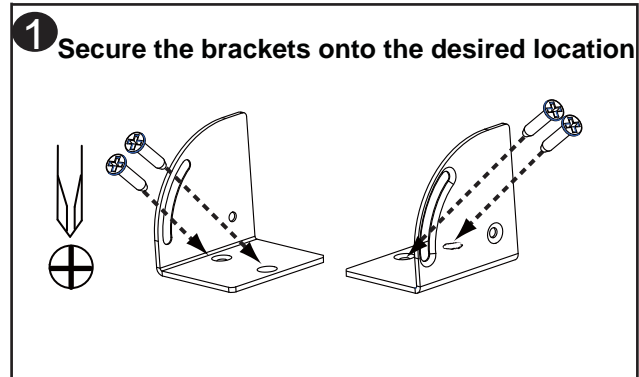

## Connect the Alarm Cable, the OSD Control Board and Programming

### Connect the Alarm Cable to the Camera

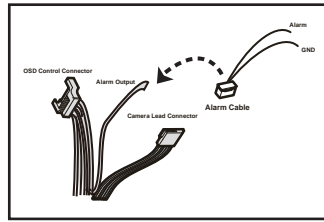

### Connect the OSD Control Board Cable to the OSD Control Board (see image below)

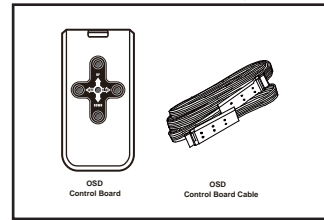

### Connect the OSD Control Board to the Camera (see image below)

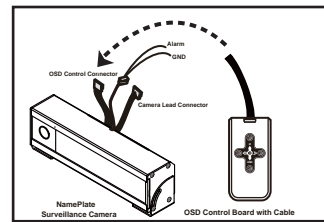

With power applied to the camera and a video monitor connected, press and hold the [ENTER] key for three seconds to access the OSD top level menu. A map of the setup menu options will be shown as the right of this sheet presented.

To navigate through the menus, use the arrow keys on the control board and use the [ENTER] key to select the menu field desired.

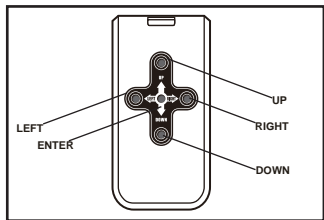

**IMPORTANT:**  
When any changes made to the camera configuration, use the "SAVE SETTINGS" option in the "SAVE/RESTORE" menu to save. Otherwise any changes made will be lost when the camera is next reset or has its power cycled.

## Control Menu Map

Press the [ENTER] key on the control board for three seconds to view the menu.

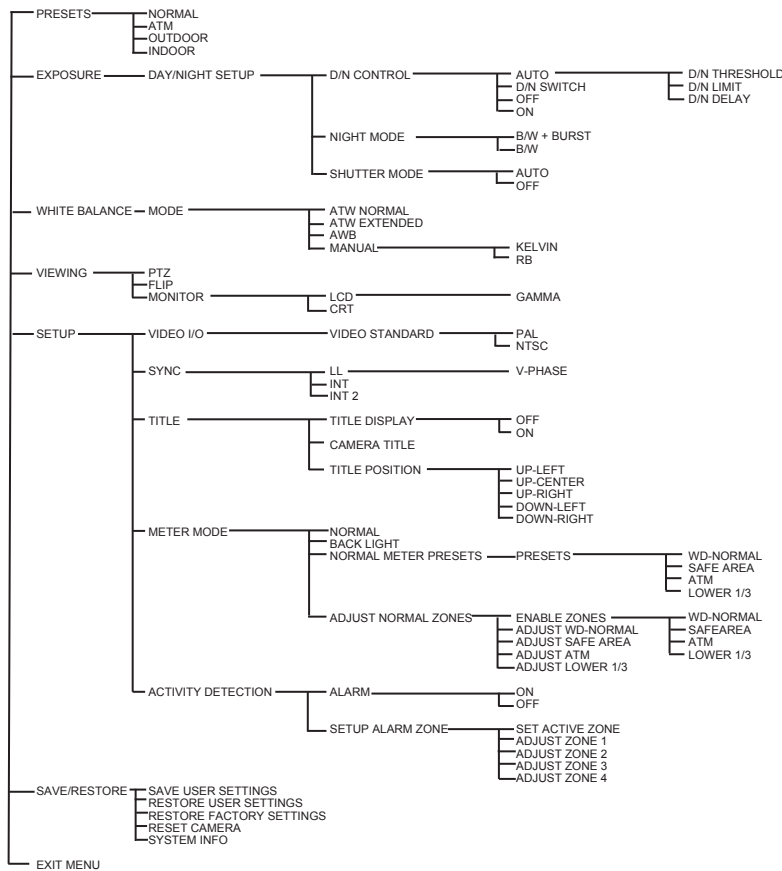

## Menu Description

**PRESETS** – There are general "factory set" configurations. Select the preconfigured mode to have the best performance for the specified environment. Press the [ENTER] key on the selected option, the pre-configured set-up parameters will be shown on screen.

**INDOOR or OUTDOOR** – These settings are optimized for indoor/outdoor lighting conditions.

**NORMAL** – This provides the most versatile settings for general purpose applications.

**ATM** – This can help to reduce the Flicker effects of this type of lighting.

**EXPOSURE- DAY/NIGHT SETUP** – This mode enables camera to acquire better images under daylight or low light conditions.

**D/N CONTROL**- Set the mode to ON or OFF, or changing from Day to Night automatically according to the ambient lighting conditions.

**NIGHT MODE** – This feature is adjustable for improving low light performance by reducing noise from the video signal. Force the camera into Night (black & white) only mode regardless of lighting conditions. B/W +Burst can be chosen to avoid incorrect judgments.

**Shutter Mode** – Shutter speed changes automatically according to the ambient lighting conditions when AUTO is selected.

**WHITE BALANCE- WHITE BALANCE** has 4 modes for selection. Each mode processes electronic shutter differently and is suitable for different environments.

**ATW Normal** – Select Auto White Balance Range, for general operation. The range is configurable with low limit (to help with reds) and high limit (to help with blues) adjustments if necessary.

**ATW Extended** – Extended Auto White Balance Range – used for scenes that may have an extremely wide range of color temperatures.

**AWB** –Auto White Balance.

**MANUAL** – Allow settings on the color temperature of the image manually. This can be achieved by using the Kelvin option. This setting is also good for static environment applications where the lighting conditions never change, for example, indoor hallways.

### VIEWING

**PTZ** – Pan, Tilt and Zoom.

**FLIP** – Mirror Image.

**MONITOR** – Select output devices: LCD or CRT.

### SETUP

**VIDEO I/O** – The function sets video frequency, PAL or NTSC.

**SYNC** – This is for sync setup.

**TITLE** – The camera can be named and displayed when operating.

### METER MODE –

**NORMAL METER PRESETS** - These are general factory set configurations. For zone adjustments, go to Adjust Normal Zones to reconfigure.

**ADJUST NORMAL ZONES** - This feature is to configure the area used for WDR light metering. Tapping the [ENTER] key reveals a WDR zone box, repeatedly tapping the [ENTER] key to change the color of the zone.

White - Move the entire zone's position.

Green - Increase the size of the zone.

Red - Reduce the size of the zone.

Use the arrow keys to adjust the zone position or size. Holding the [ENTER] key for 3 seconds to go to the previous menu. The default settings already provide good general performance. If adjustment is necessary, change zone size according to the area of interest making sure to include all areas of interest. This will dictate how the overall wide dynamic range features operate.

**Example:**

An internal scene viewing a daylight streaming in doorway and polished floor. It is needed to monitor any movements; people enter the doorway and follow them to the left hand side of the picture. The door way is central to the image. Thus the box should be sized and positioned to cover the doorway and the left area where people walk.

### SAVE/RESTORE

**SAVE USER SETTINGS** – Save any programming changes to ensure they are retained after power loss or reset. If changes are not saved, the camera will revert to the previous settings on power-up.

**RESTORE USER SETTINGS** – This will undo any changes made since the last "Save Setting".

**RESTORE FACTORY SETTINGS** – Restore camera settings to factory default – full reset, all previous program will be lost, including video standard setups, and to the default setting, NTSC.

**RESET CAMERA** – This is a soft reset and has the same effect as cycling the camera power.

**SYSTEM INFO** – Display the camera firmware version.

### EXIT MENU

Select and exit OSD menu when the setup is complete. Make sure the user setting is saved before exiting.

## ATM Camera Specifications

Image Picture Element	Pixim Seawolf 1/3" Sensor
Effective Picture Element	758(H) x 540(V)
Resolution	690 HTVL-E
Minimum Illumination	50IRE: 0.6 Lux@F1.2
S/N Ratio	>50dB
Wide Dynamic Range	120 dB / 17bit
Wide Dynamic Range Area	1 Zone - Fully Adjustable
Slow Shutter	Auto, x2, x4, x8, x16, x32, x64
Electronic Shutter	WDR Control (Auto)
Day/Night	ON, OFF, AUTO
White Balance	Normal, Extended, Manual
Auto White Balance Range	2800k~9100k(Normal) 2000k~11000k(Ex)
Sync System	Internal / Line Lock(AC Only)
Video Output	1.0 Vpp BNC 75Ω unbalanced
Alarm Output	Trigger Voltage 3.3V, 15mA
Power Range	24VAC ± 20% 12VDC ± 10%
Power Consumption	12VDC: 2W Dual Power: 2.88W
Operating Temperature	-10°C ~ +60°C
Storage Temperature	-30°C ~ +80°C

## Lens Specifications

Focal Length	2.9mm	
F-No.	F2.0	
Iris Range	Fixed Range	
Angle Of View	Diagonal	122.1°
	Horizontal	96.6°
	Vertical	71.9°

## Regulatory Compliance

Emissions	FCC part 15 Class B CE: EN55011 ICES-003 EN55022 CISPR 11 CISPR22 ANSI C63.4
Immunity	CE: EN50130-4
Safety	CSA C22.2



### FCC COMPLIANCE:

This equipment complies with Part 15 of the FCC rules for intentional radiators and Class B digital devices when installed and used in accordance with the instruction manual. Following these rules provides reasonable protection against harmful interference from equipment operated in a commercial area. This equipment should not be installed in a residential area as it can radiate radio frequency energy that could interfere with radio communications, a situation the user would have to fix at their own expense.

### CISPR 22 WARNING:

This is a Class B product. In a domestic environment this product may cause radio interference in which case the user may be required to take adequate measures.

### POWER SUPPLY REQUIREMENTS:

For use with listed Audio/Video Product and only connected to 15W or less power supply. Power supply should be a NEC Class 2 / LPS Supply.

### EQUIPMENT MODIFICATION CAUTION:

Any equipment changes or modifications not expressly approved by the seller could cause a hazardous condition and invalidate FCC compliance, thus voiding the users authority to operate the equipment.